

SPECIFICATION FOR APPROVAL

承 认 书

| | |
|---------------------------------|---------------------------|
| CUSTOMER 客户名称: | NUMBER 编 号: Y-21070207 |
| DESCRIPTION 品 名: 贴片共模电感 | QUANTITY 数 量: 10pcs |
| PART NO. 型 号: BCDM126-2-472T | DATE 日 期: 2021/7/2 |
| CUSTOMER PART NO. 客户料号: | NOTE 注 解: |

| |
|------------------------------|
| APPROVAL SIGNATURE 客户承认签章 |
| |

| APPROVED BY 核 准 | Q. C. DEPT. 品 管 | CHECKED BY 核 查 | DRAWN BY 制 作 |
|--------------------|--------------------|-------------------|-----------------|
| | | | |

深圳市宝创达电子有限公司

SHENZHEN BAOCHUANGDA ELECTRONICS CO., LTD.

地址: 深圳市龙华区观澜街道横坑河西村77号A栋2楼
Add: 2nd floor building A no.77 hexi village guanlan
Street longhua district shenzhen

Tel: 0755-29736760

Fax: 0755-28056434

| | | | |
|----------------|--|-----------------|----------------|
| 客户 CUSTOMER | | 规格型号 PART NO | BCDM126-2-472T |
|----------------|--|-----------------|----------------|

1: 外形尺寸: (单位: mm)

OVERALLDIMESSON (UNIT:mm)

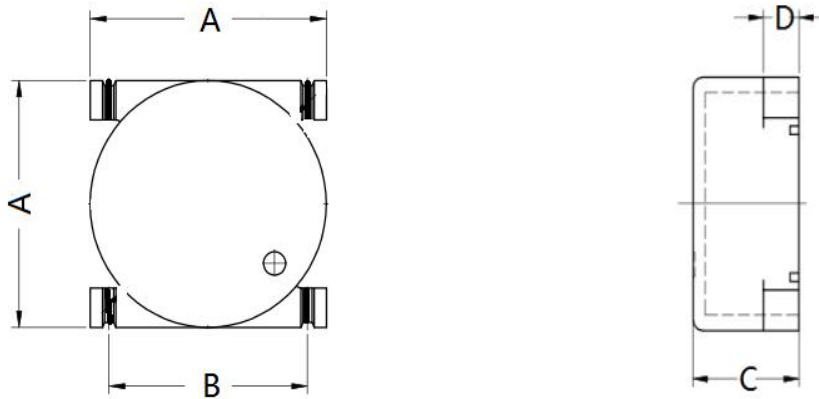

| | | | | |
|------|---------|----------|--------|-------|
| 尺寸 | A | B | C | D |
| 单位mm | 13.0MAX | 10.5±0.5 | 6.5MAX | 2±0.5 |

2: 接线图: 两组线分绕

WIRING DIAGRAM: SEPARATE WINDING

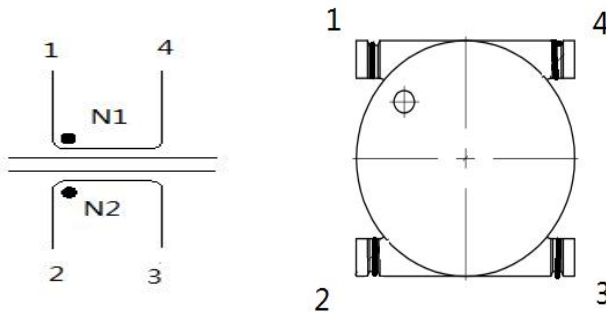

No polarity

3: 焊接尺寸: mm

WELDING DIMENSION: mm

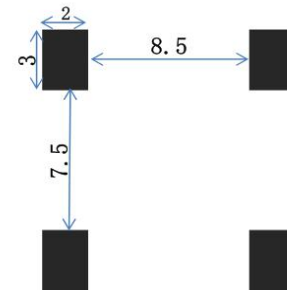

4: 电气性能参数(ELECTRICAL PARAMETERS)

| | |
|---------------------------|---------------------|
| 电感量及允许偏差 (10KHz/ 0.1V) | L12=L34: 4.7mH(MIN) |
| 直流电阻 DC RESISTANCE | 220 mΩ (MAX) |
| 额定电流 RATED CURRENT | 0.4A MAX |
| 阻抗(2MHz) IMPEDANCE | 4700Ω MIN |

测试仪表 (MEASUREMENT INSTRUMENT):

HM2791 HM2801 HP4285
CH19073

在最坏情况下建议零件的温度不超过+125° C。(It is recommended that the temperature of the part does not exceed +125° C under worst case conditions.)

贮存环境(Storage conditions):存放环境温度-20° C至60° C,相对湿度不高于70%,并存放在不含硫和氯的空气气氛中(请不要直接暴露在阳光下) Storage ambient temperature-20° C to 60° C, 70%RH or less, and isolate the parts from sulphic and chloric atm osphere. (Please don't expose to the sun directly)

| | |
|-------|----------------------------------|
| Note: | SPEC. NO. : Y-21070205 1/2 |
|-------|----------------------------------|

| | | | |
|----------------|--|-----------------|----------------|
| 客户 CUSTOMER | | 规格型号 PART NO | BCDM126-2-472T |
|----------------|--|-----------------|----------------|

零件工作温度(Operating temperature of parts): -40° C - 125° C

温升 (Temperature Rise) : < 55K

电性能试验条件 (Est conditions of Electrical Properties) : 20° C、相对湿度33%
(20° C, 33% RH)

没有特殊规定下 (If not specified differently)

5: 阻抗曲线图 (IMPEDANCE CURVE)

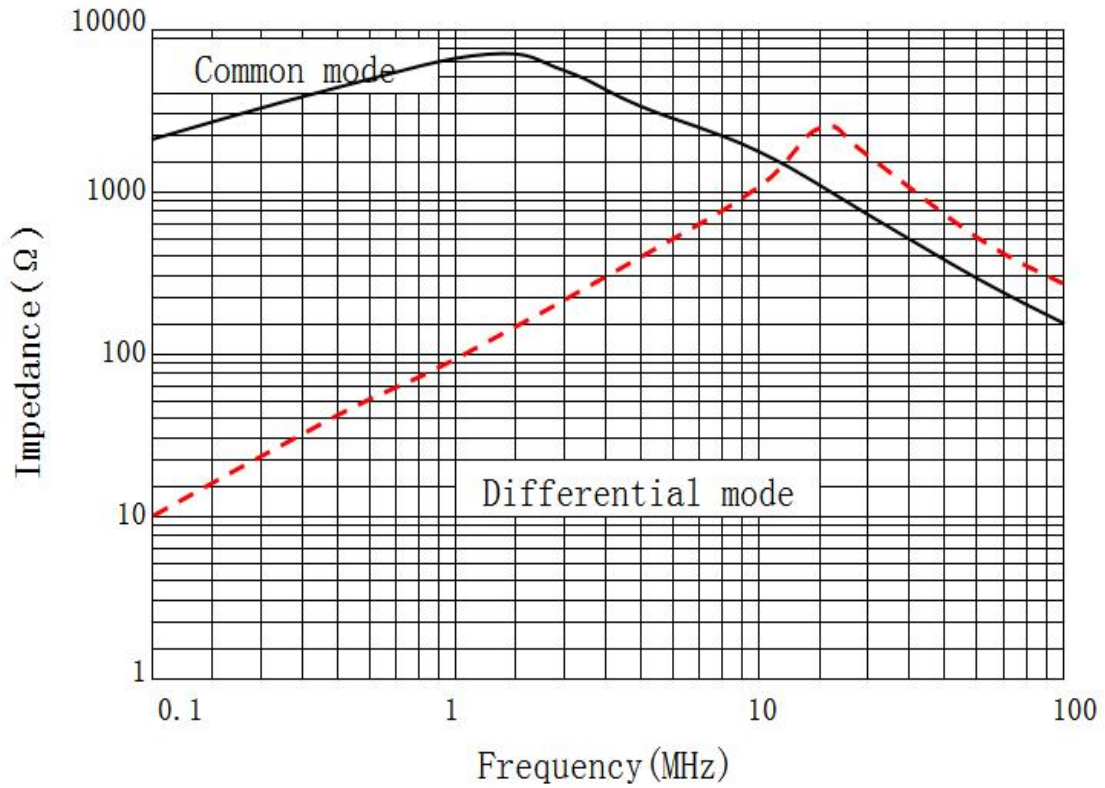

6: 包装 (PACKING)

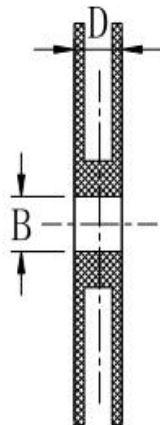
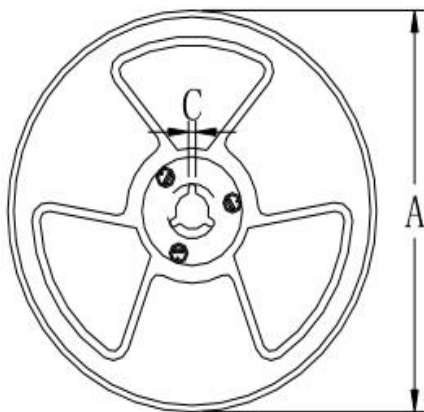

| 规格 | 13" | 7" |
|----|------------|-----------|
| 尺寸 | | |
| A | Φ 330±2.0 | Φ 178±2.0 |
| B | Φ 90 ± 2.0 | |
| C | 2.3 | |
| D | 30.5 | |

| | |
|-------|----------------------------------|
| Note: | SPEC. NO. : Y-21070207 2/2 |
|-------|----------------------------------|